

HSF RoHS

REV	ECN NO	DESCRIPTION	DATE	NAME
A		NEW		

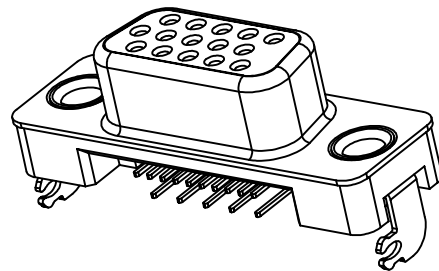
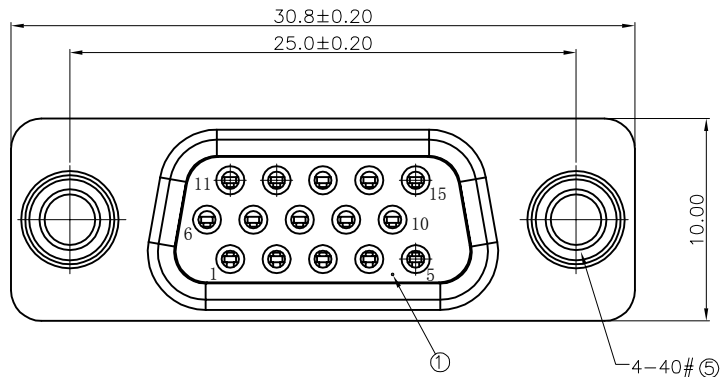

1. SPECIFICATION

ELECTRICAL CHARACTERISTICS:

- Contact Current Rating: 3Amperes
- Dielectric withstanding Voltage: AC 1000V, for 60sec
- Insulation Resistance: 1000 Milliohms Minmum. at DC 500V
- Contact Resistance: 25 Milliohms Maximum
- Operating Temperature: -55° C to +105° C

2. ORDER INFORMATION

- Insertion Force: 4.0kg/max
- Pull out Force: 0.8kg/min
- Retention Force: 0.5kgf/per pin min

Ordering Information

L88213- 1 X 01 X

- | | |
|----------|------|
| 电镀规格 | 包装类型 |
| 0=Au0.8" | A=袋装 |
| 1=Au1" | B=管装 |
| 2=Au1.5" | C=盘装 |
| 3=Au2" | D=卷装 |
| 4=Au3" | |
| 5=Au5" | |
| 6=Au10" | |
| 7=半金锡 | |
| 8=镀亮锡 | |
| 9=镀雾锡 | |

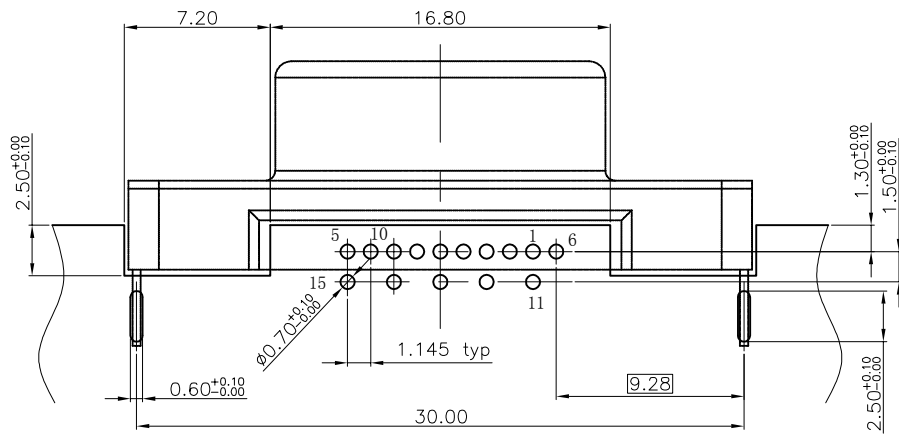
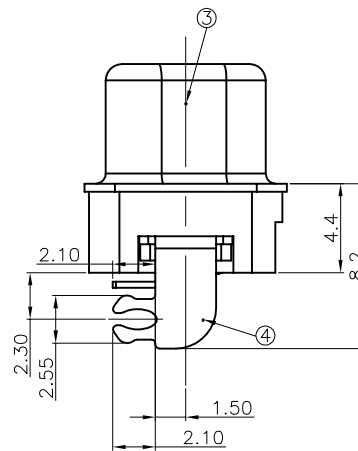
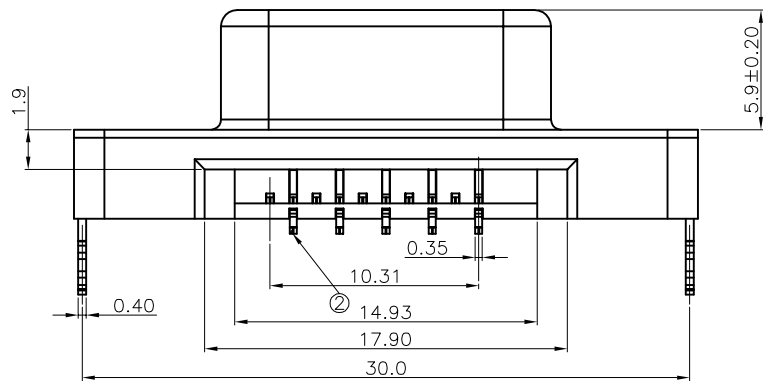

Recommended PCB Layout(±0.05)

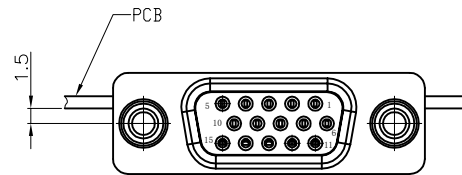

NO.	DESCRIPTION	QTY	MATERIAL	PLATING
5	NAL	2	BRASS	Ni-Plating
4	GND	2	BRASS	Ni-Plating
3	SHELL	1	SPCC	Ni-Plating
2	CONTACT	15	BRASS	Au-Plating
1	HOUSING	1	LCP/PBT	

LDCONN 东莞连大精密制品有限公司
DongGuan LianDa Precision Products Co., LTD

STANDARD TOLERANCE (EXCEPT SPECIFIED)	
LINER	ANGLES
.0 ±0.30	0.° ±3°
.00 ±0.25	.0° ±2°
.000 ±0.15	.00° ±1°

TITLE	VGA 15P Female Forward H5.9mm	DRAWN BY	Lujunhui	18.04.07
PART NO	L88213-1X01X	CHECKED BY		
DRAWING NO		APPROVED BY		
SCALE	1:1	UNIT	mm	PAGE 1/1
				SIZE A4