

# HW0310 Connector 0.3mm Pitch H1.0

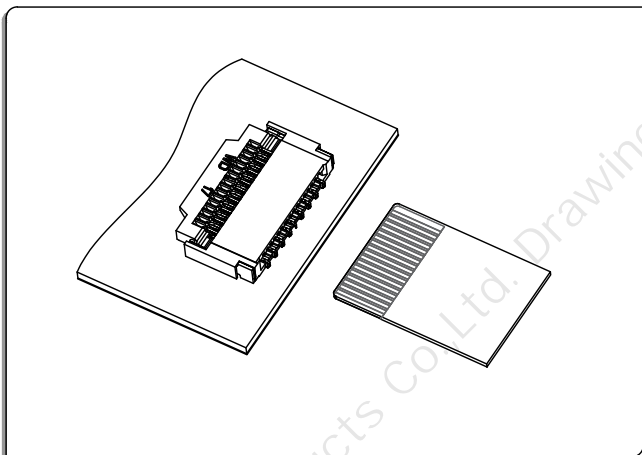

## ● 技术参数 SPECIFICATIONS

- 1、极数CKT: 13Pin to 71Pin
- 2、额定电流Current rating: 0.2A AC/DC
- 3、额定电压Voltage rating(max): 30V, AC/DC
- 4、工作温度Working Temperature: -25℃~+85℃, (含通电温度上升值)  
(Including temperature rise in applying electrical current)
- 5、接触电阻Contact resistance: 初始Initial value  $\leq 40m\Omega$   
环境测试后After environmental testing  $\leq 60m\Omega$
- 6、绝缘电阻Insulation resistance:  $\geq 50M\Omega$
- 7、耐电压Withstand voltage: 500VAC(rms)
- 8、适用基板厚度Applicable PC board thickness: 1.6mm to 2.0mm

## ● 安装尺寸 Mounting Measurement

### ● Assembly Layout

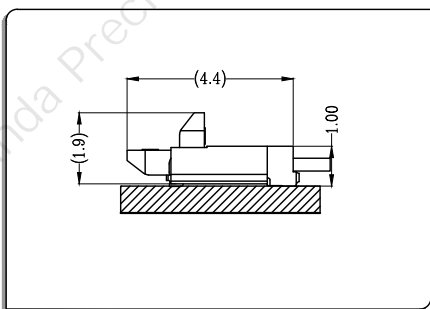

### ● Applicable Flat Cable

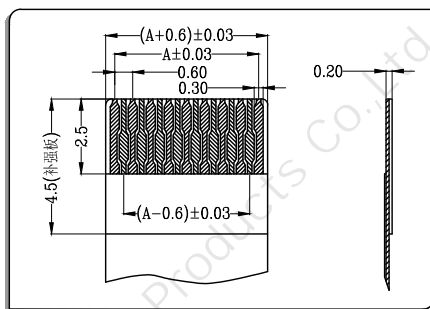

### ● P. C. B Layout

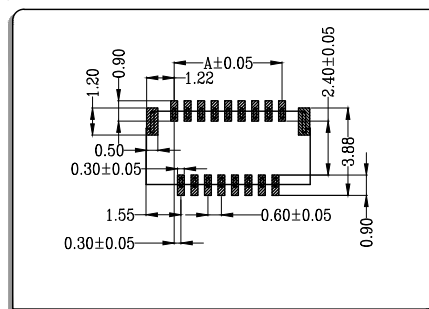

## ● 后压卧式 Back Flip R/A

### ● 材料与表面处理 Material and Finish:

Housing:LCP UL94V-0 & Terminal:phosphor bronze & Fitting:phosphor bronze; Finish:Tin-plated & Gold-plated

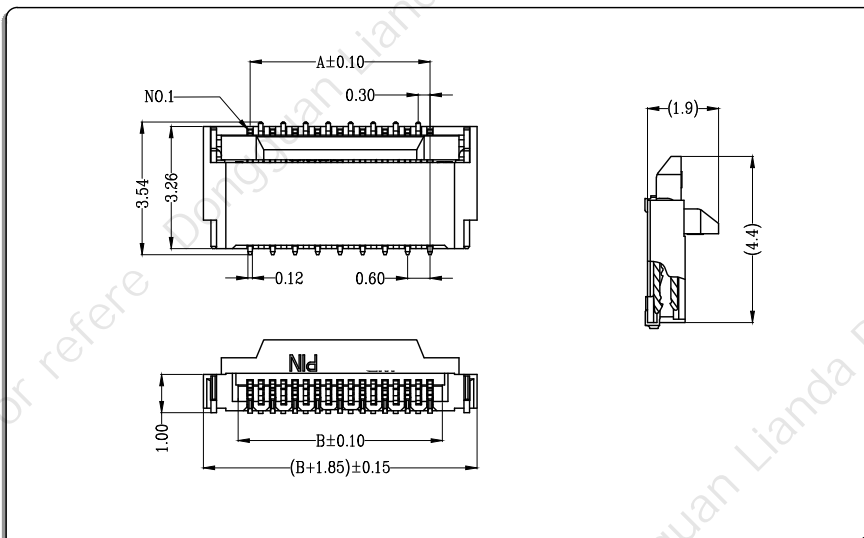

CKT	Part No	DIM A	DIM B
13	HW03102-13	3.60	4.25
15	HW03102-15	4.20	4.85
17	HW03102-17	4.80	5.45
19	HW03102-19	5.40	6.05
21	HW03102-21	6.00	6.65
23	HW03102-23	6.60	7.25
25	HW03102-25	7.20	7.85
27	HW03102-27	7.80	8.45
29	HW03102-29	8.40	9.05
31	HW03102-31	9.00	9.65
33	HW03102-33	9.60	10.25
—	—	—	—
71	HW03102-71	21.00	21.65