

XW0520 Connector 0.5mm Pitch H2.0

FPC
0.5

XW0520 Connector 0.5mm Pitch

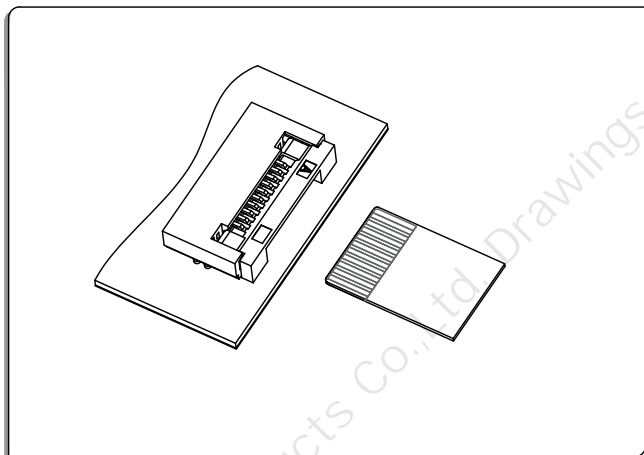

● 技术参数 SPECIFICATIONS

- 1、极数CKT: 4Pin to 65Pin
- 2、额定电流Current rating: 0.5A AC/DC
- 3、额定电压Voltage rating(max): 50V, AC/DC
- 4、工作温度Working Temperature: -25°C~+85°C, (含通电温度上升值)
(Including temperature rise in applying electrical current)
- 5、接触电阻Contact resistance: 初始Initial value $\leq 30m\Omega$
环境测试后After environmental testing $\leq 50m\Omega$
- 6、绝缘电阻Insulation resistance: $\geq 500M\Omega$
- 7、耐电压Withstand voltage: 500VAC(rms)
- 8、适用基板厚度Applicable PC board thickness: 1.6mm to 2.0mm

● 安装尺寸 Mounting Measurement

● Assembly Layout

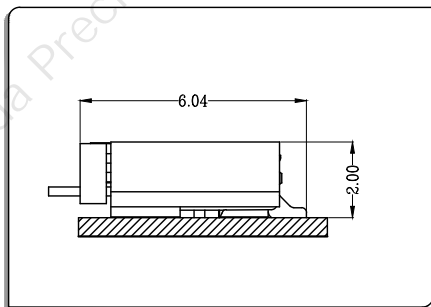

● Applicable Flat Cable

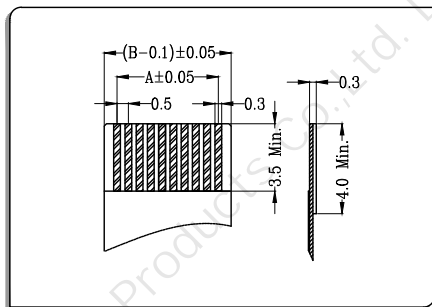

● P.C.B Layout

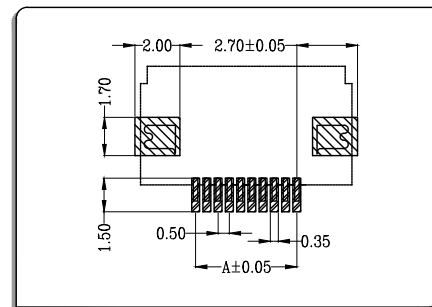

● 掀盖卧式 Easy-on R/A

- 材料与表面处理 Material and Finish:
Housing:LCP UL94V-0 & Terminal:phosphor bronze &
Fitting:Brass; Finish:Tin-plated & Gold-plated

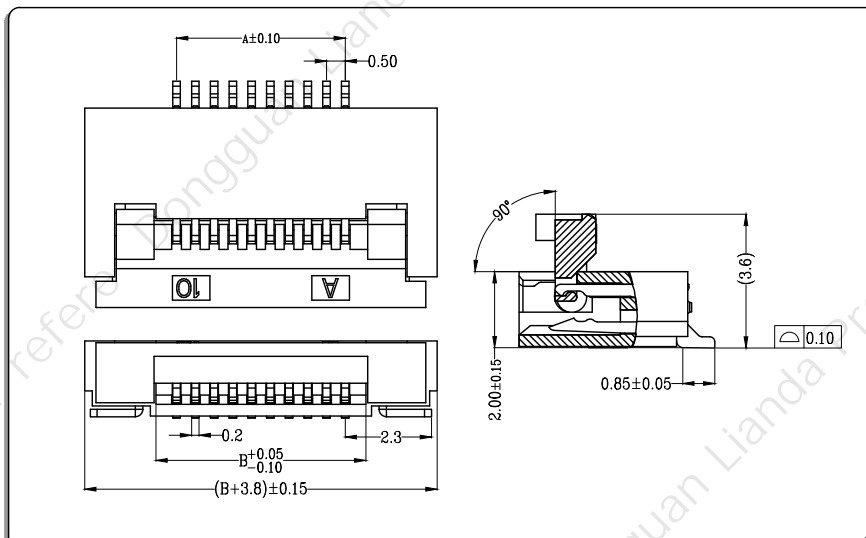

CKT	Part No.	DIM A	DIM B
4	XW05202-04	1.50	2.60
5	XW05202-05	2.00	3.10
6	XW05202-06	2.50	3.60
7	XW05202-07	3.00	4.10
8	XW05202-08	3.50	4.60
9	XW05202-09	4.00	5.10
10	XW05202-10	4.50	5.60
11	XW05202-11	5.00	6.10
12	XW05202-12	5.50	6.60
13	XW05202-13	6.00	7.10
14	XW05202-14	6.50	7.60
--	-- --	--	--
65	XW05202-65	32.00	33.10