

# HW0520 Connector 0.5mm Pitch H2.0

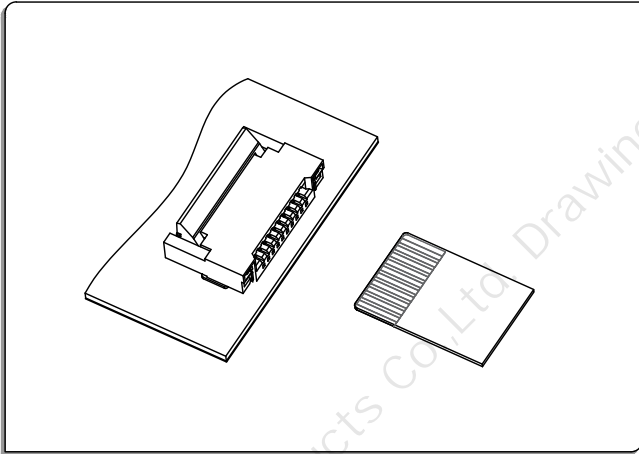

## ● 技术参数 SPECIFICATIONS

- 1、极数CKT: 4Pin to 80Pin
- 2、额定电流Current rating: 0.5A AC/DC
- 3、额定电压Voltage rating(max): 50V, AC/DC
- 4、工作温度Working Temperature: -25℃~+85℃, (含通电温度上升值)  
(Including temperature rise in applying electrical current)
- 5、接触电阻Contact resistance: 初始Initial value  $\leq 30\text{m}\Omega$   
环境测试后After environmental testing  $\leq 50\text{m}\Omega$
- 6、绝缘电阻Insulation resistance:  $\geq 500\text{M}\Omega$
- 7、耐电压Withstand voltage: 500VAC(rms)
- 8、适用基板厚度Applicable PC board thickness: 1.6mm to 2.0mm

## ● 安装尺寸 Mounting Measurement

### ● Assembly Layout

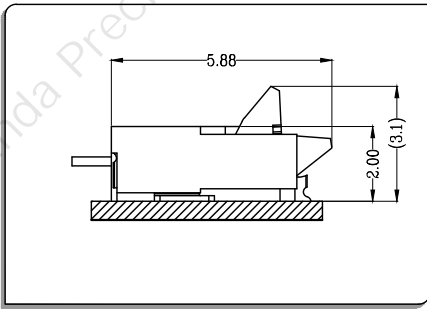

### ● Applicable Flat Cable

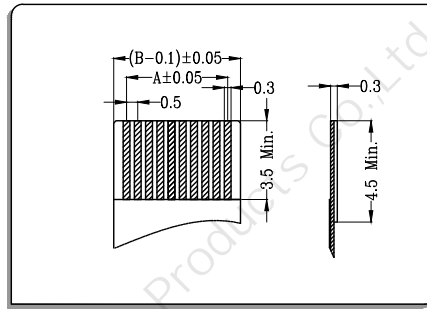

### ● P. C. B Layout

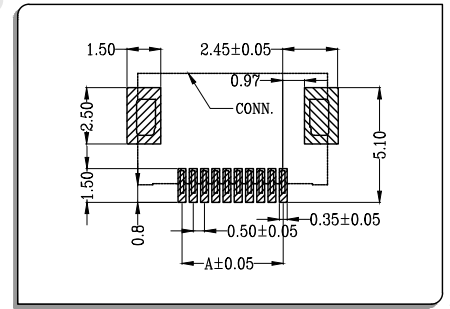

## ● 后压卧式 Back Flip R/A

### ● 材料与表面处理 Material and Finish:

Housing:LCP UL94V-0 & Terminal:phosphor bronze & Fitting:phosphor bronze; Finish:Tin-plated & Gold-plated

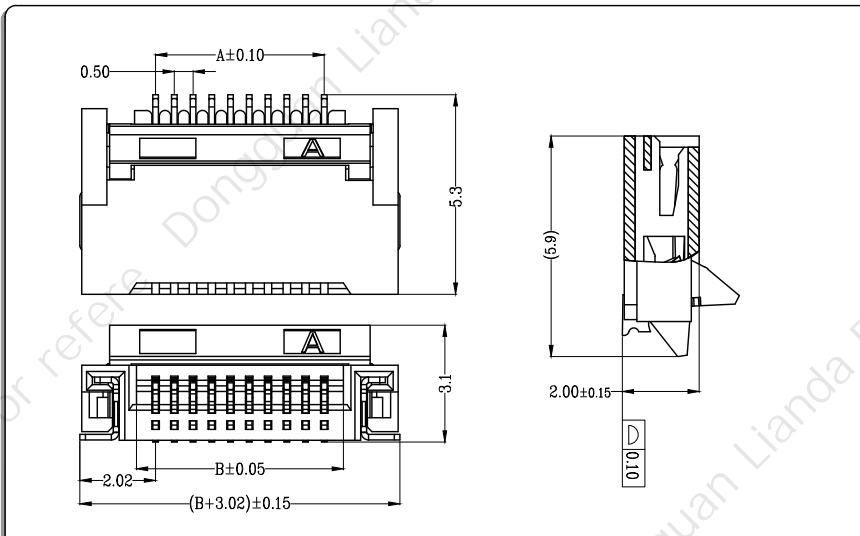

CKT	Part No	DIM A	DIM B
4	HW05200-04	1.50	2.52
5	HW05200-05	2.00	3.02
6	HW05200-06	2.50	3.52
7	HW05200-07	3.00	4.02
8	HW05200-08	3.50	4.52
9	HW05200-09	4.00	5.02
10	HW05200-10	4.50	5.52
11	HW05200-11	5.00	6.02
12	HW05200-12	5.50	6.52
13	HW05200-13	6.00	7.02
14	HW05200-14	6.50	7.52
--	--	--	--
80	HW05200-80	39.50	40.52